

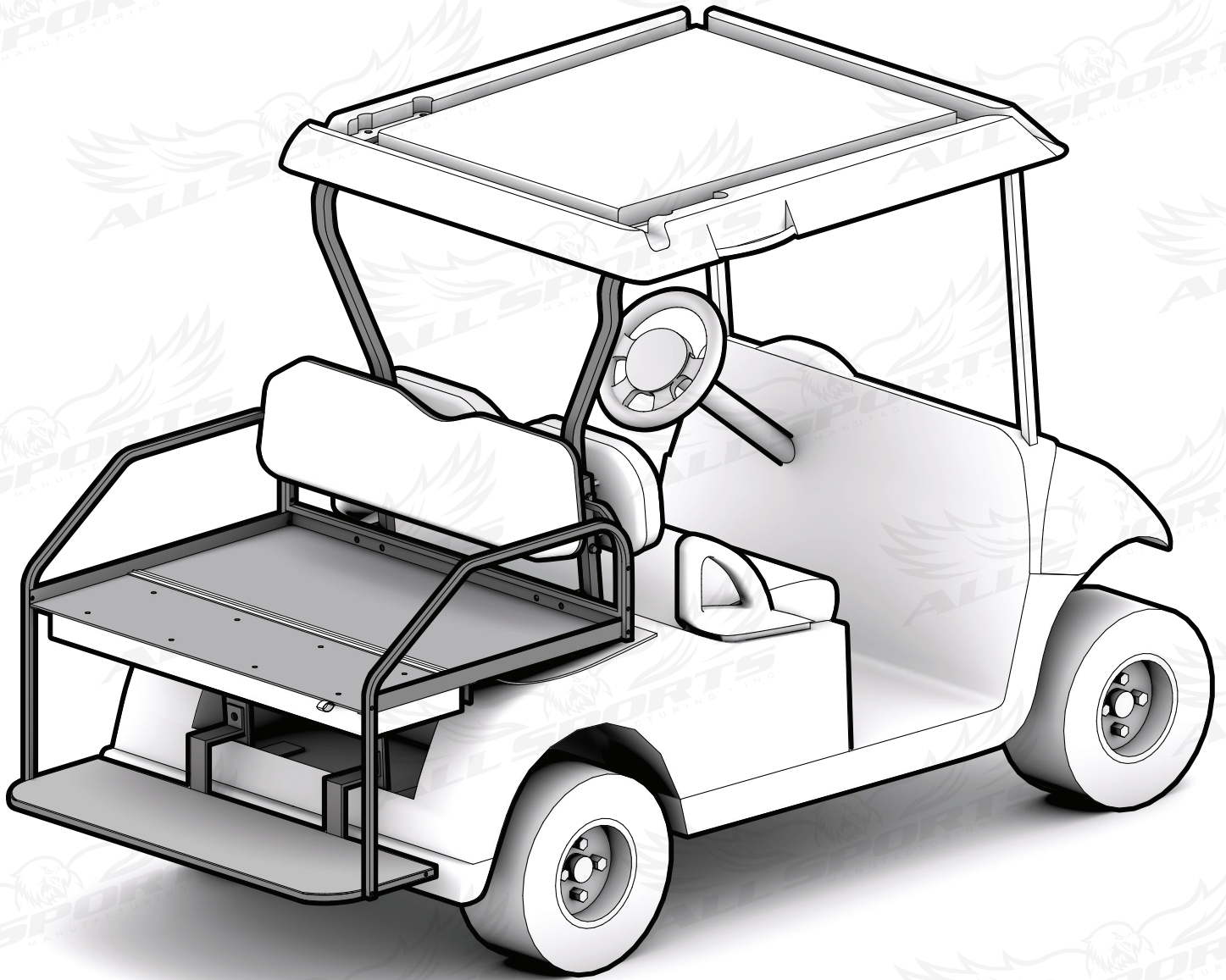

**RXV**

# **Rear Flip Seat Kit**

instruction manual



1-866-291-5244



# Parts List

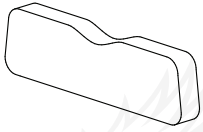

Back Pad (1)

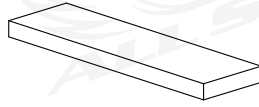

Seat Pad (1)

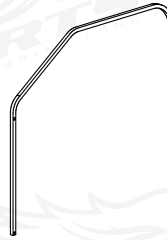

Side Frame (2)

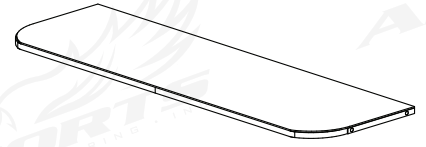

Step Plate (1)

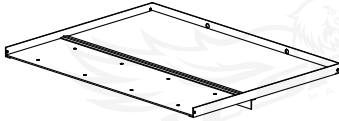

Flip Seat Frame (1)

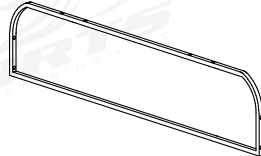

Back Frame (1)

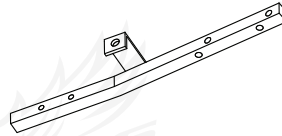

Front Supports(2)

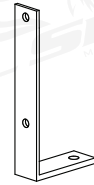

Rear Support

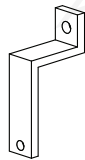

Step Plate Supports(2)

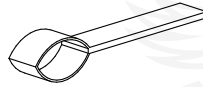

Seat Pull(1)

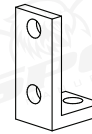

Rear Seat Supports(2)

## Bolts

Allen Bolt 1" (8)

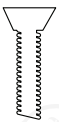

1/4" x 1" (8)



1/4" x 1 3/4" (8)



5/16" x 1" (4)

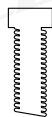

5/16" x 1 1/2" (4)



5/16" x 2" (4)



5/16" x 2 1/2" (4)



5/16" x 1 1/4" (2)

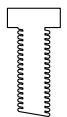

1/4" Washer (16)



5/16" Washer (36)

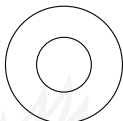

3/8" Washer (2)

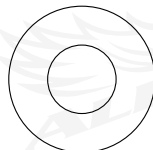

1/4" Nyloc Nut (4)



5/16" Nyloc Nut (16)

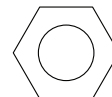

5/16" Acorn Nut (2)

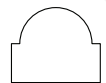

\*Parts not shown in proportion.

# Installation

1. Remove sweater basket and front cushion.

2. Remove roof supports.

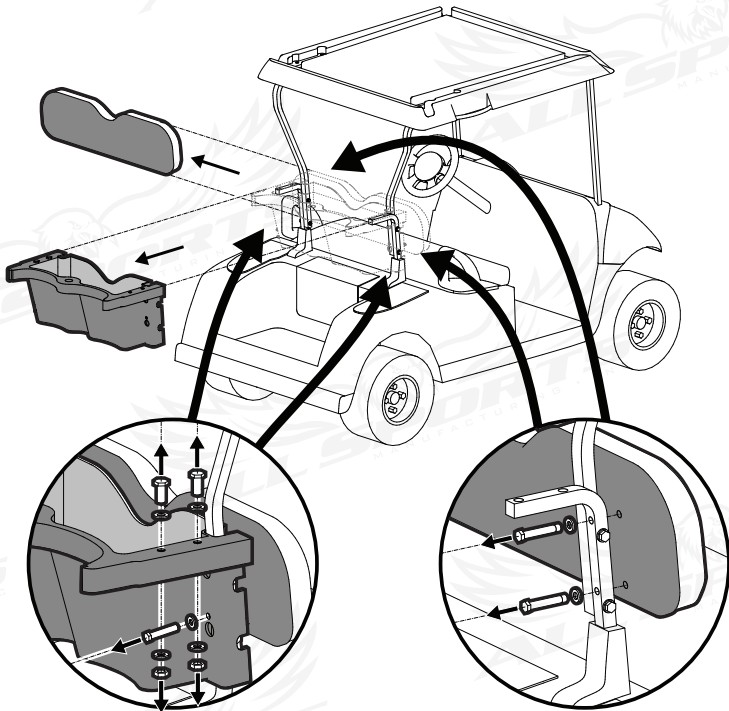

Remove bolts connecting sweater basket to seat supports.

Remove bolts connecting front seat cushion to seat supports.

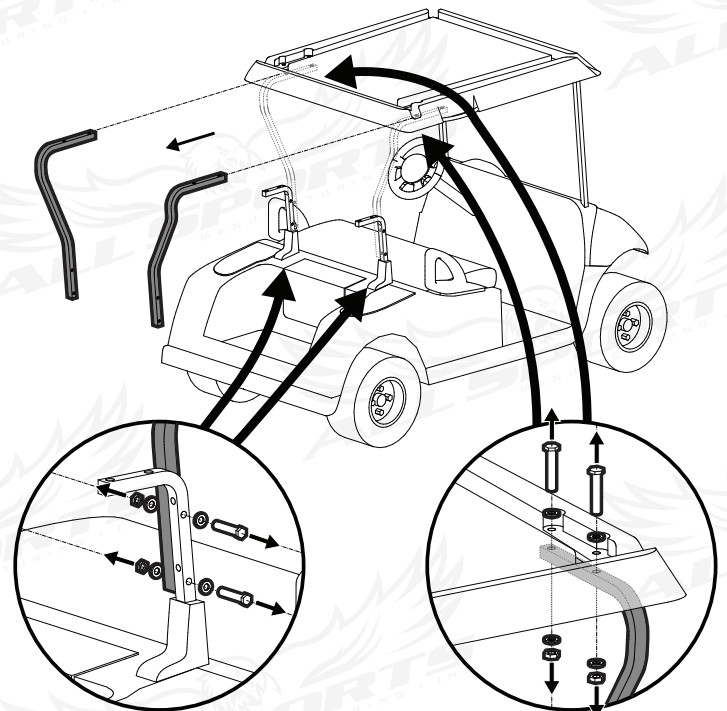

Remove bolts connecting sweater basket to seat supports.

Remove bolts connecting front seat cushion to seat supports.

3. Remove access panel and seat supports.

4. Install frame supports and access panel.

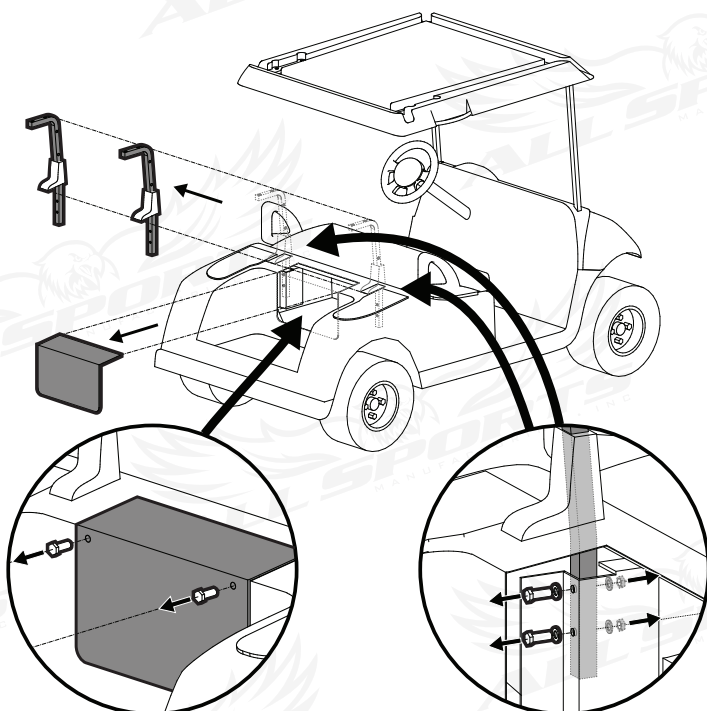

Remove screws connecting access panel to cart body.

Remove bolts connecting seat supports to rear frame plates. To access nuts, lift up front seat pad.

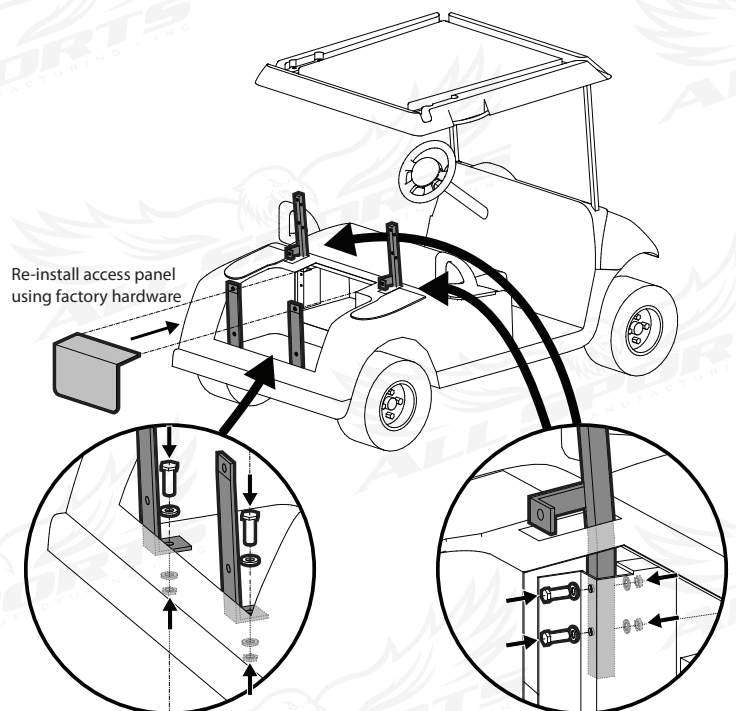

Re-install access panel using factory hardware

Drill bagwell holes to 3/8". Bolt rear frame supports to bagwell using 5/16" x 2" bolts, washers, and nuts.

Bolt front supports to rear frame plates using factory hardware.

Parts not shown in proportion.



# Installation

## 5. Install seat frame.

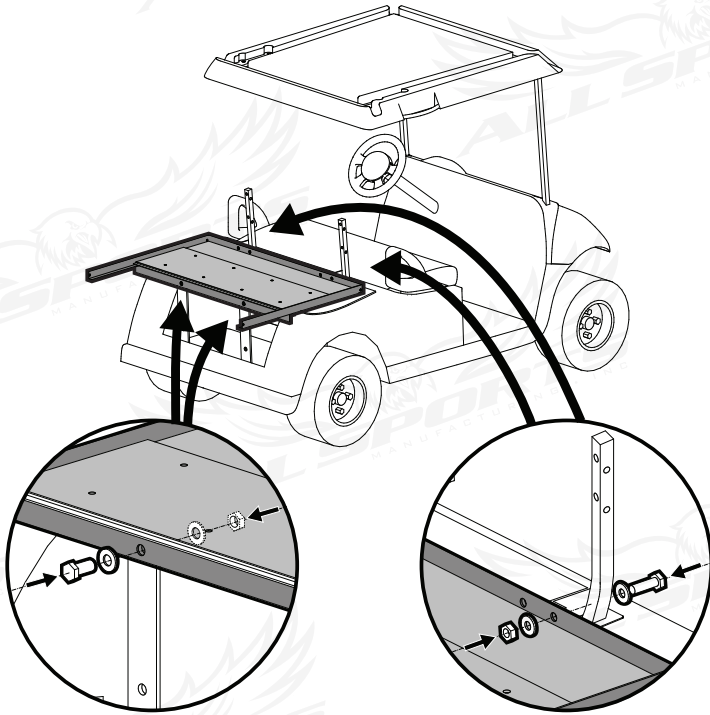

Bolt rear supports to underside of flip seat frame with 5/16" x 1" bolts, flat washers, and nuts.

Bolt front supports to outer side of flip seat frame with 5/16" x 1" bolts, flat washers, and nuts.

## 6. Install side rails.

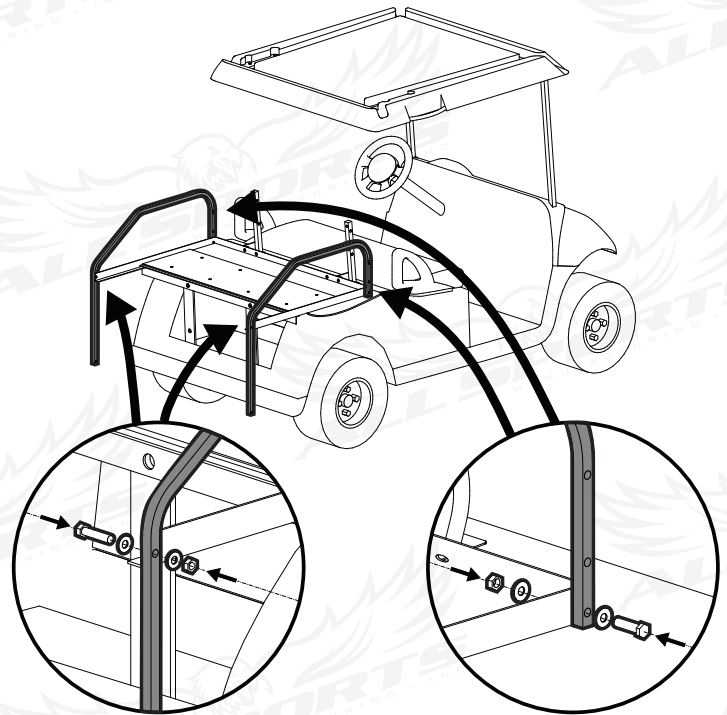

Bolt side rails to rear of flip seat frame with 5/16" x 2" bolts, flat washers, and acorn nuts.

Bolt side rails to front of flip seat frame with 5/16" x 2" bolts, flat washers, and nyloc nuts.

## 7. Install back frame.

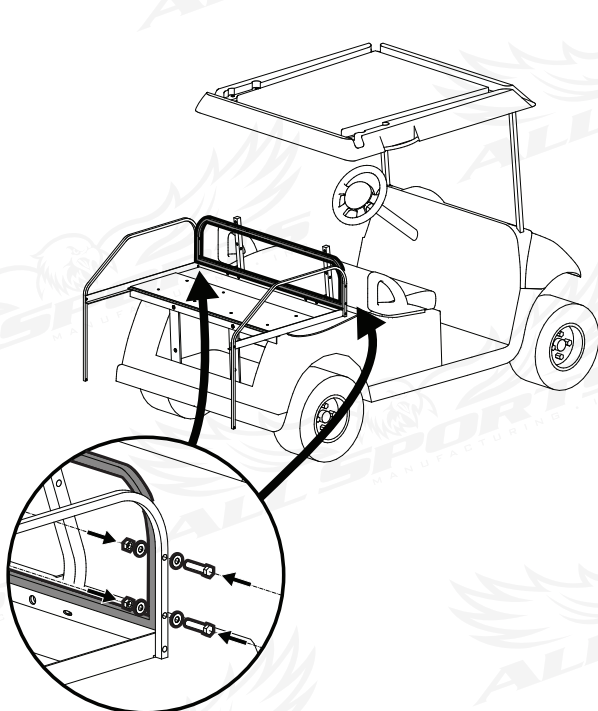

Bolt back frame to side rails with 5/16" x 2 1/2" bolts, flat washers, and nuts.

## 8. Install step-plate.

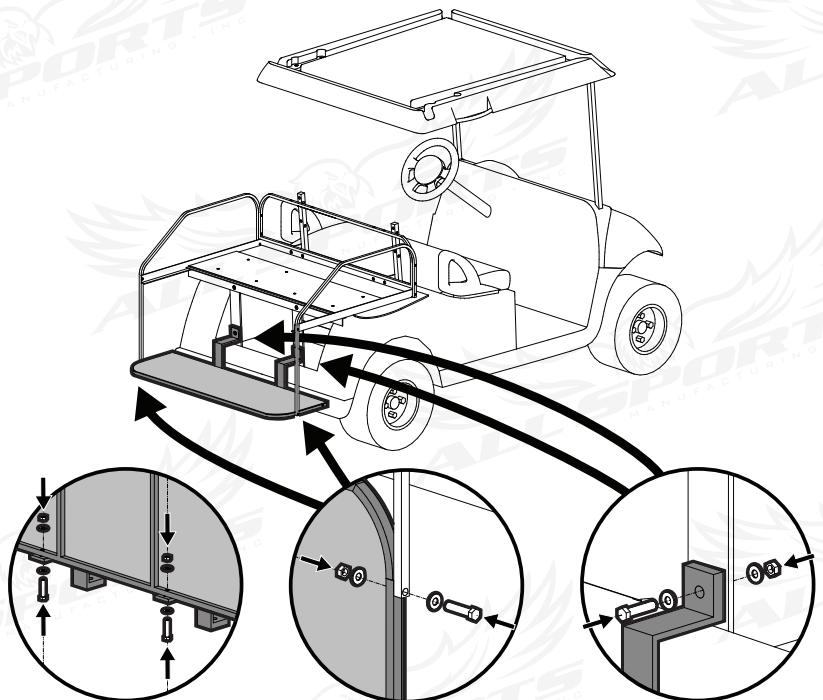

Bolt step supports to step plate with 5/16" x 2" bolts, flat washers, and nyloc nuts.

Bolt step plate to side frames with 5/16" x 2" bolts, flat washers, and nyloc nuts.

Bolt step plate to rear supports with 5/16" x 1" bolts, flat washers, and nyloc nuts.

# Installation

9. Re-install roof supports and front cushion.

10. Install rear seat back pad.

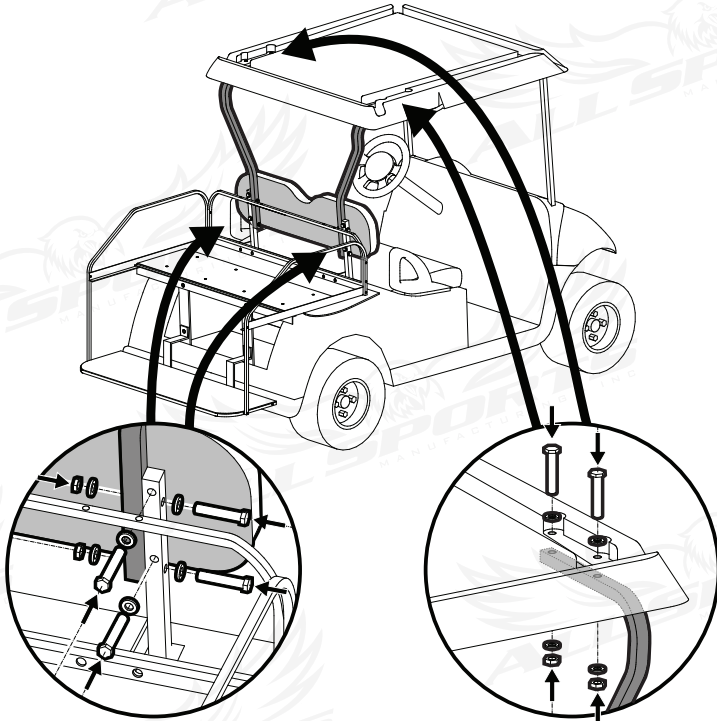

Bolt roof supports and front cushions to front supports using factory hardware.

Bolt roof supports to roof using factory hardware.

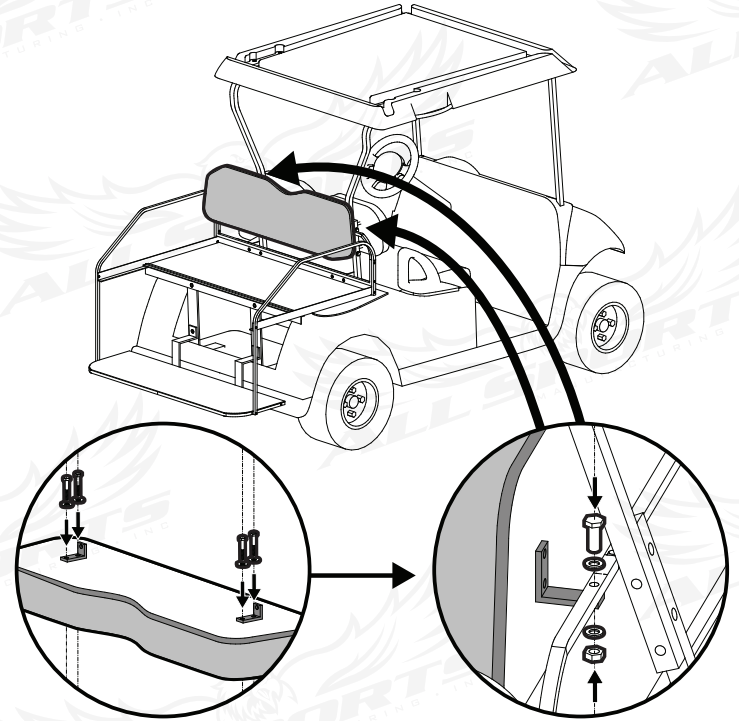

Bolt rear seat supports to back of rear seat back pad using 1/4" x 1" bolts and flat washers.

bolt rear seat back pad to back frame using 1/4" x 1 3/4" bolts, flat washers, and nuts.

11. Install flip-seat pad.

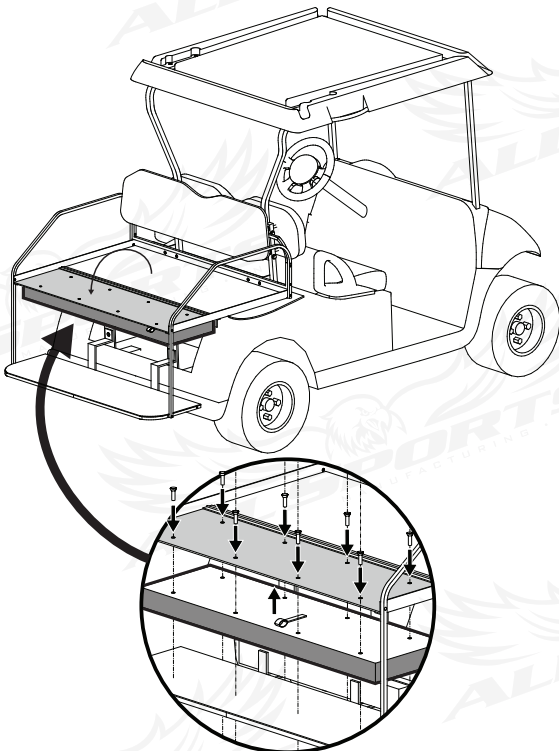

Attach flip seat pad to underside of cargo panel with allen bolts(8). Secure seat pull in between pad and panel.